

Design of Compact U-Slot Circular Patch Antenna on RT DUROID 5880 Substrate

*¹K.V.L.Bhavani, ¹B.T.P.Madhav, ¹P.Poorna Priya, ¹V.V.S.Murty,
²K.Ravikumar, ³Srujana Adusumilli

¹Department of ECE, K.L.University, Guntur, A.P, India

²Department of ECM, K L University, Guntur, A.P, india

³Project Student Department of ECE, K L University, Guntur, A.P, india

Abstract-- This paper presents design and analysis of compact wire edge fed U-shape slot antenna. The proposed antenna has simple structure consisting U-shape slot on a circular patch of radius 13.1mm. The patch is designed on circular shape RTD substrate material of radius 13.2mm, with height of 5mm and whose permittivity is 2.2. By using only single patch a high impedance bandwidth is achieved. Simulated results show that the return loss is -16.15dB at the center frequency of exactly 3.282GHz and the simulated impedance bandwidth (VSWR<2) is 24%. The antenna is designed and simulated using CONCERTO software and theoretical results give good agreement with simulated results. Return loss, 2D, 3D gain, E and H Field distributions, pointing vector, polar plots, FD probe results, Electric and magnetic energy distribution, and quality factor are simulated for the proposed designed antenna was presented.

Keywords: U-slot micro strip patch antenna, circular patch, RTD substrate.

I. INTRODUCTION

Microstrip patch antenna in its simplest form consists of a radiating patch on one side of a dielectric substrate and a ground plane on the other side. Radiation from microstrip antennas occurs from the fringing fields between the edge of the microstrip antenna conductor and the ground plane [1]. Extensive research and development of microstrip antennas and arrays, exploiting the numerous advantages such as light weight, low volume, low cost, planar configuration, compatibility with integrated circuits have led to develop the proposed design model [2]. The proposed antenna design operates at 3.282GHz finds applications in the S-band which includes Microwave devices/communications, wireless

LAN, communication satellites, WLAN(Wi-Fi 802.11 a/n), wimax, Radars [3].

The disadvantage of MSPA is narrow bandwidth. To improve the bandwidth recent research efforts have been devoted. A high permittivity substrate could be used but this approach increases the coupling between the antenna and the ground plane. Embedding a suitable U-shaped slot in circular shape radiating patch is a very effective method for achieving a wide bandwidth. Several U-slot patch antennas have been reported recently to improve bandwidth [4-6]. In this paper U-slot is designed on circular patch to achieve more compactness and high impedance bandwidth.

Conventional Microstrip patch antenna designs with thick substrate layer causes major problem associated with impedance matching. The proposed antenna is designed on RT duroid 5880 substrate material which is low density, high weight material for high performance weight sensitive applications. The very low dielectric constant of RT/duroid 5880 laminates is uniform from panel to panel and is constant over a wide frequency range. Applications include airborne antenna system, light weight feed network, military radar systems, missile guidance system and point to point digital radio antennas [7].

The proposed antenna is designed using Concerto software. It is a state of the art system for high frequency field simulation. The main components are modeler, quickwave simulator, quickwave2D, CLASP, SOPRANO/EV and post processor. This provides a complete tool chain for RF and microwave electromagnetic design for use on 32 or 64 bit windows platform. Modeller is used to generate data and models for electromagnetic simulation [8].

II . DESIGN EQUATIONS

Fig 1 shows the circular patch MSPA.

A. Fields and currents: With no current sources the wave equation may be written as

$$(\nabla^2 + K^2)\vec{E} = 0 \text{ where } K = \omega\sqrt{\mu\epsilon}$$

Solution of the wave equation in cylindrical coordinates is

$$E_z = E_0 J_n(K\rho) \cos n\phi$$

Magnetic field components are

$$H_\rho = \frac{j}{\omega\mu} \frac{1}{\rho} \frac{\partial E_z}{\partial \phi} = -\frac{J_n}{\omega\mu\rho} E_0 J_n'(K\rho) \sin n\phi$$

$$H_\phi = \frac{-j}{\omega\mu} \frac{\partial E_z}{\partial \rho} = -\frac{jk}{\omega\mu} E_0 J_n'(K\rho) \cos n\phi$$

$$E_\rho = E_\phi = H_z = 0$$

$\vec{K} = \hat{n} \times \vec{H} = \hat{\rho} H_\phi - \hat{\phi} H_\rho$ (Surface currents on the circular disk) at the edge of surface current $K_\rho(\rho=a) = H_\phi(\rho=a) = 0$

B. Resonant frequency

Resonant frequency of disk antenna for TM_{nm} mode may be evaluated from

$$f_r = \frac{K_{nm} C}{2\pi a_e \sqrt{\epsilon_r}}$$

Where K_{nm} the derivative of the Bessel function of order n & c is velocity of light.

a_e is effective radius =

$$a \left[1 + \frac{2b}{\pi a \epsilon_r} \left(\ln \frac{\pi a}{2b} + 1.7726 \right) \right]^{\frac{1}{2}}$$

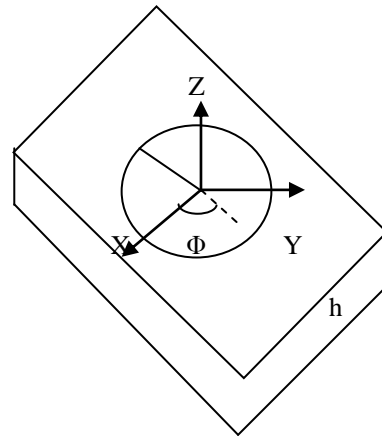

Fig 1. Circular MSPA

III ANTENNA DESIGN SPECIFICATION:

The geometrical configuration of the proposed U shape slot circular microstrip patch antenna is shown in Fig 2. Table 3.1 gives dimensions of the each element used to design the patch

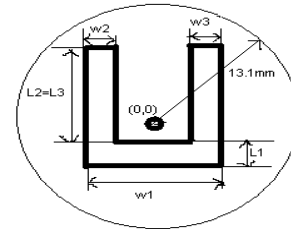

Fig 2: U shape rectangular microstrip patch

S.No	Element	shape	Total Dimension (mm)	Xaxis (mm)	Yaxis (mm)
1	Patch	circular	Radius=13.1mm, height=0.05mm	0	0
2	slot1 (bottom)	rectangular	L1=4.6, w1=9	-4.5 to 4.5	-7.9 to -3.3
3	slot2 (left)	rectangular	L2=6, w2=2.6	-4.5 to -1.9	-3.3 to -9.3
4	Slot3 (right)	rectangular	L3=6, w3= 2.6	1.9 to 4.5	-3.3 to 9.3
4	Substrate	circular	Radius=13.2mm, height=5mm	0	0
5	Ground	circular	Radius=13.2mm, height=0.05mm	0	0

6	Feed (dp)	Wire edge	Length=2,r adius=0.1	0	0
---	-----------	-----------	-------------------------	---	---

Table 3.1 U shape slot circular MSPA design values

Fig 2 shows U-shape slot circular patch designed on circular shape RT duroid substrate of radius 13.2mm whose permittivity value is 2.2 and 5mm height.

Fig 3a shows the top view of the designed patch model in CONCERTO and Fig 3b shows the side view of the designed patch.

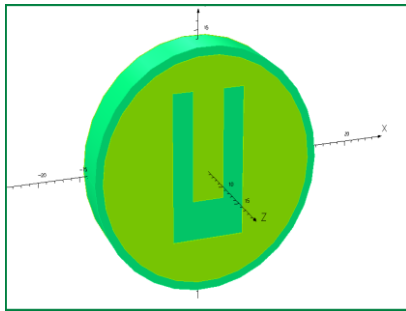

Fig 3a CONCERTO model for U shape slot circular microstrip patch antenna (top view)

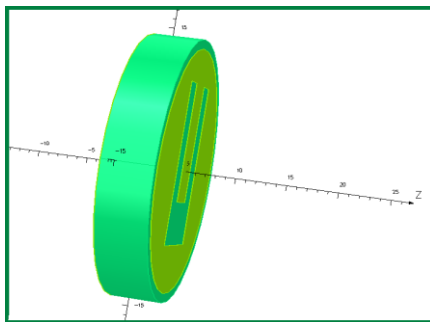

Fig 3b CONCERTO model for U shape slot circular microstrip patch antenna (side view)

The proposed antenna is fed at center (0,0). Wire edge feeding is used to reduce the complexity.

Fig 4 shows the side view of the proposed design with wire edge feeding.

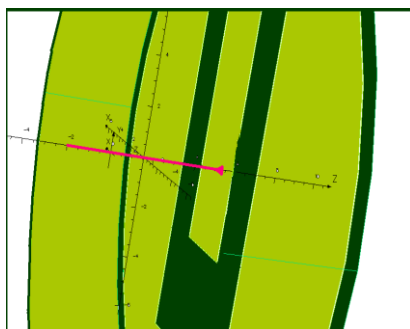

Fig 4: Feed location

IV. RESULTS AND DISCUSSION:

A. Return loss vs frequency

A good antenna might have a value of -10dB return loss as 90 % of the signal is absorbed and 10% is reflected back [10]. The proposed u-slot circular patch antenna is giving the excellent return loss curve in S-band. The curve has deep and wide dip at the center frequency of 3.282GHz. Fig 5 shows the return loss Vs frequency curve.

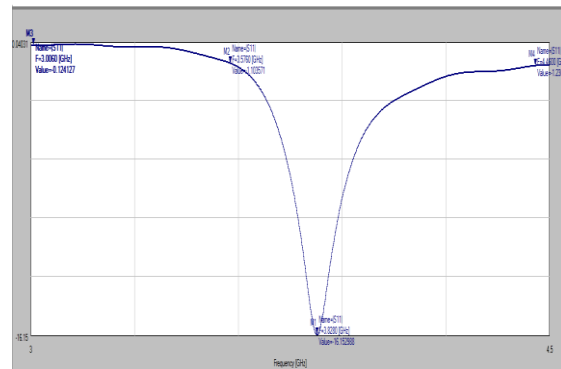

Fig 5: Return loss Vs frequency: -16.15dB at 3.282GHz.

B. 3D radiation pattern

Antennas will radiate the signal in one direction than others, so the gain is the amount of the power that can achieve in one direction at the expense of power lost in others [10]. Fig 6 shows 3D radiation pattern. Gain value obtained as 6.059dB

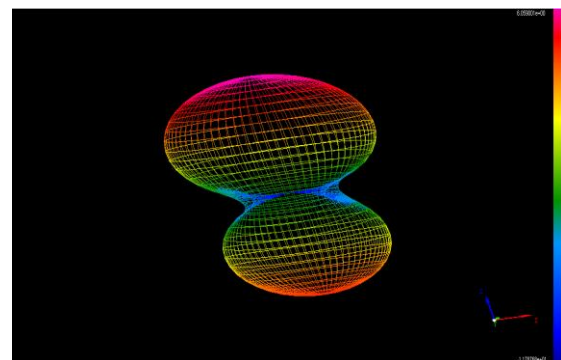

Fig 6: 3D radiation pattern: gain is 6.059dB

C. Radiation results in line form and polar form

Fig 7a and Fig 7b shows the radiation results in linear form when $\Phi=0^0$, $\theta = -90^0$ to 90^0 and when $\Phi=90^0$, $\theta = -90^0$ to 90^0 respectively.

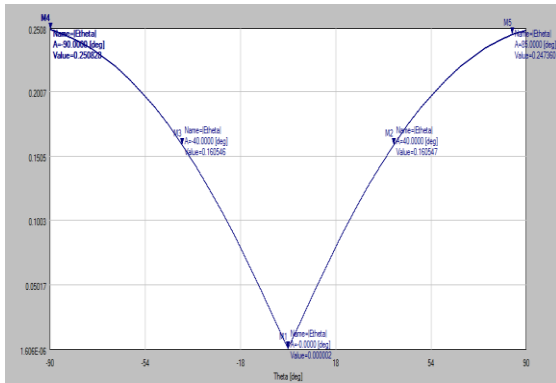

Fig 7a: Line form when $\Phi=0^0$ & $\theta =-90^0$ to 90^0

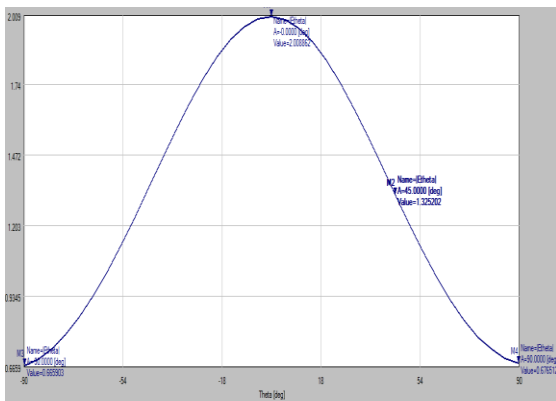

Fig 7b: Line form when $\Phi=90^0$ & $\theta =-90^0$ to 90^0

Fig 8a and Fig 8b shows the radiation results in polar form when $\Phi=0^0$, $\theta = -90^0$ to 90^0 and when $\Phi=90^0$, $\theta = -90^0$ to 90^0 respectively.

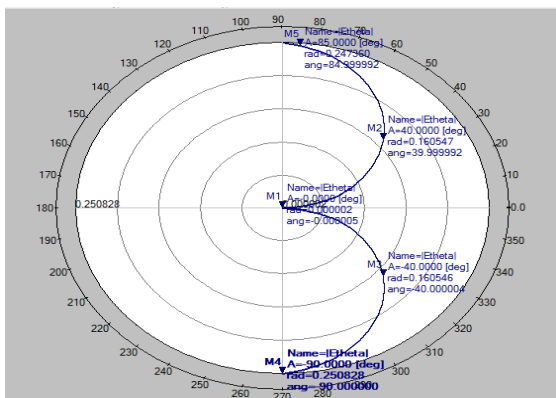

Fig 8a: polar results when $\Phi=0^0$ & $\theta =-90^0$ to 90^0

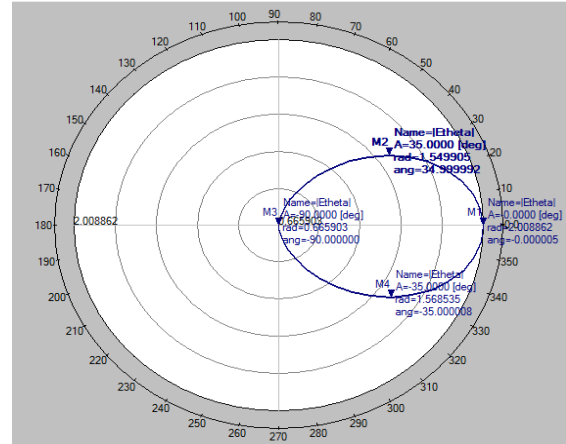

Fig 8b: polar results when $\Phi=90^0$ & $\theta =-90^0$ to 90^0

D. Field distributions and pointing vector:

Fig 9a, Fig 9b and Fig 9c shows the Electric field (E), magnetic field (H) and pointing vector $S=EXH$ respectively. It is observed that E-field distribution: $1.306327e^{-02}$ v/mm, H-field distribution: $1.937525e-02$ (A/mm) and Pointing vector: $3.754288e^{-06}$ W/mm²

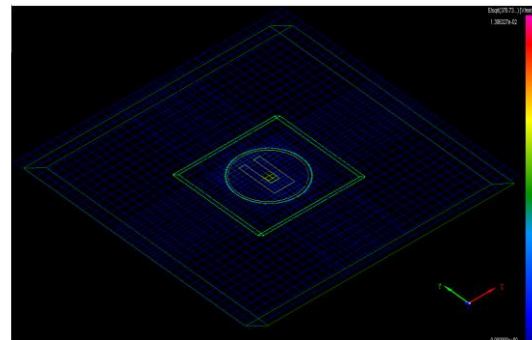

Fig 9a:E-field distribution : $1.30633e^{-02}$ v/mm

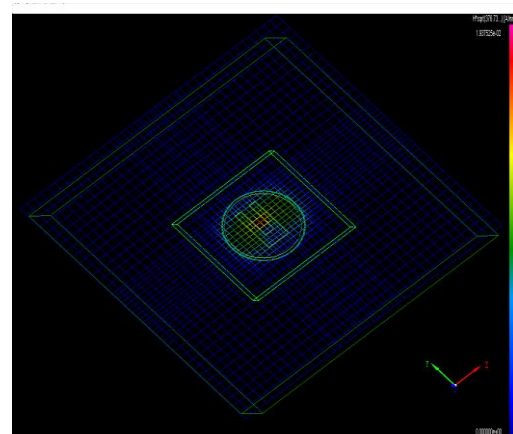

Fig 9b:H-field distribution : $1.9375e^{-02}$ (A/mm)

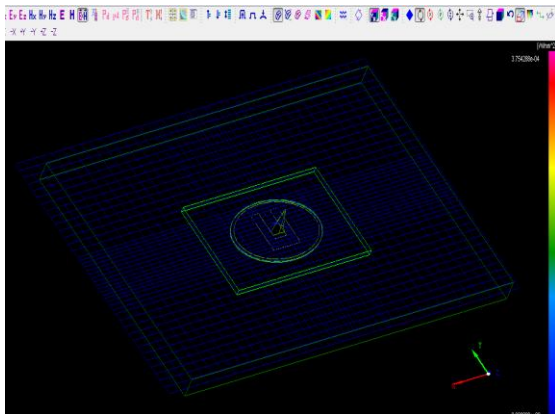

Fig 9c: Pointing vector: $3.754288e^{-06}$ W/mm²

E. Energy (Electric and magnetic) and quality factor: Fig 10 shows the energies and Q-factor

File (J)	MIN	MAX	AIR
Electric	0	0	0
Magnetic	0	0	0
Total	0	0	0

Energy (J)	MIN	MAX	AIR
Electric	$4.491267e-005$	$4.491267e-005$	$4.491267e-005$
Magnetic	0.004391183	0.004391183	0.004391183
Total	0.00440309	0.00440309	0.00440309

Q-factor	Q _e	Q _m	Q ₀
	$1.2345678e-10$	$1.2345678e-10$	$1.2345678e-10$

Fig 10: Energy and quality factor: Electric energy $4.491267e-005$ J Magnetic energy 0.004391183 J and total energy 0.00440309 J and quality factor is $1.2345678e-10$

F. FD probe results:

Fig 11a and Fig 11b shows that FD probe results in linear form and polar form respectively.

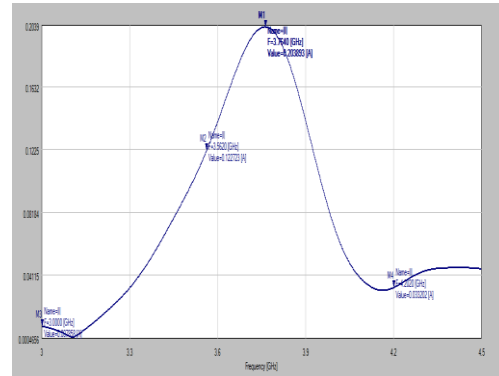

Fig 11a: FD probe results line form

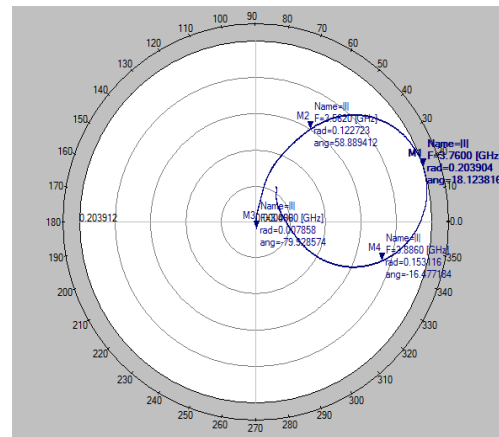

Fig 11b: FD probe results in polar form

V. CONCLUSIONS

In this paper the S-band U slot circular patch MSPA was designed by using RT duroid 5880 substrate material. From the simulated results, we can see that this proposed design giving good return loss of -16.15 dB at 3.282 GHz with high bandwidth. Main advantage of the proposed design is its compactness because of the circular patch shape so it can be used for all S-band applications includes wireless and Radar systems.

VI. ACKNOWLEDGEMENTS

The authors like to express their thanks to the management and department of ECE, K L University for their support and encouragement during this work.

VII. REFERENCES

[1]J.J.Bahl, P.Bhartia, "Microstrip Antennas Handbook", Artech House microwave library, 2000

[2] KIN-LU Wong, "Compact and broadband microstrip antennas", text book, John Wiley & Sons, Inc.

[3] *K.V.L.Bhavani, B.T.P.Madhav, P.Poorna priya, Prof. Habibulla Khan, G.Manoj Kumar, N.Durga Indira, "Gain Enhanced E- Shape Microstrip Patch Antenna at 2 GHZ on Air Substrate", International Journal of Advances in Science and Technology, ISSN 2229 5216 , Vol. 2, No.6, pp 51-58, June-2011.

[4] J A Ansari, Satya Kesh Dubey and Prabhakar Singh "Analysis of U-slot loaded Patch for Dual band Operation "International journal of microwave and optical technology vol. 3, no. 2, April 2008

[5] Wenwen Chail, Xiaojuan Zhang, and Jibang Liu "A Novel Wideband Antenna Design Using U-slot "PIERS online, vol. 3, no. 7, 2007

[6] RG Madhuri, PM Hadalgi, and SL Mallikarjun "U-Slot Rectangular Dielectric Resonator Antenna for Wideband Applications "International Journal of Electronics Engineering, 2 (2), 2010, pp. 249 – 252

[7] B.T.P. Madhav, V.G.K.M. Pisipati, K. Sarat Kumar, Habibulla Khan, "Comparative Study of Microstrip Rectangular Patch Array Antenna on Liquid Crystal Polymer and Rt-Duroid Substrates" International Journal of Electronics and Communication Engineering. ISSN 0974-2166 Volume 4, Number 2 (2011), pp.161-170

[8] www.concerto.com

[9] K.V.L.Bhavani, B.T.P.Madhav, P.Poorna Priya, Y.Joseph Manoj Reddy, N.Srinivas Sri Chaitanya, N.Krishna Chaitanya, ANALYSIS OF ORTHOGONAL FEED DUAL FREQUENCY RECTANGULAR MICROSTRIP PATCH ANTENNA FOR S-BAND APPLICATIONS, International Journal of Advances in Engineering Research <http://www.ijaer.com/> (IJAER) 2011, Vol. No. 1, Issue No. V, June ISSN: 2231-5152

[10] B.T.P.Madhav, VGKM Pisipati, K. Sarat Kumar, K.V.L.Bhavani, VGNS Prasad, "Log-periodic Toothed Planar Antenna on LCP for Ultra Wide Band Application" ,(IJAEST) International journal of advanced engineering sciences and technologies Vol No. 5, Issue No. 1, 062 – 066(2011) ISSN: 2230-7818

Author's Details:



K.V.L.Bhavani was born in India. A.P., in 1985. She received the B.Tech, M.Tech degrees from A.N.U., A.P., India in 2006, 2009 respectively. She is

pursuing her PhD in Microstrip Patch Antennas from K L University. From 2006 to till date she is working as Assistant professor in ECE branch K.L. University. She published Five International, one national Journal paper and five national conference papers. Her research interests include antennas and wireless communications.



B.T.P.Madhav was born in India, A.P, in 1981. He received the B.Sc, M.Sc, MBA, M.Tech degrees from Nagarjuna University, A.P, India in 2001, 2003, 2007, and 2009 respectively. From 2003-2007 he worked as lecturer and from 2007 to till date he is working as Assistant professor in Electronics Engineering. He has published more than 35 papers in International and National journals. His research interests include antennas, liquid crystals applications and wireless communications.



P.Poorna priya is working as Assistant professor in the ECE Department of KL University. Priya completed her M.Sc from Andhra University and M.Tech from KL college of Engineering. She is pursuing her PhD in Microstrip Slot Antennas from K L University. She published one International, one national Journal paper and two national conference papers She has been Involved in Teaching from last three years to UG students. Her field of Interest is in Communication systems, antennas and Image Processing.



V.V.S.Murthy was born on 02 January, 1981. He received his B.E. and M.Tech degrees in 2002 and 2006 respectively. He is a life member of IETE and ISTE. His research areas include Antennas and Radio wave propagation and optical image processing. Currently he is working as Associate Professor in ECE department of K.L. University, Guntur.